



FICHA TECNICA DEFENSAS SC

1000.0000-Td-0201aes_rev1

Rev.	Fecha	Descripción	Redactado	Comprobado	Aprobado
0	23/11/2015	Primera emisión	BFA	DBL	GEB
1	18/07/2016	Revisión General	BFA	DBL	GEB



1. DEFENSAS SC



Características

Gran capacidad de deformación

Diseño fuerte y duradero

Grandes escudos pueden ser instalados

Aplicaciones

Todo tipo de atraques (lateral, en duque de alba...)

Todo tipo de muelles (pilotes duques de alba, ...)

Todo tipo de barcos (Cargueros, petroleros, cruceros, gaseros, ...)

2. DIMENSIONES

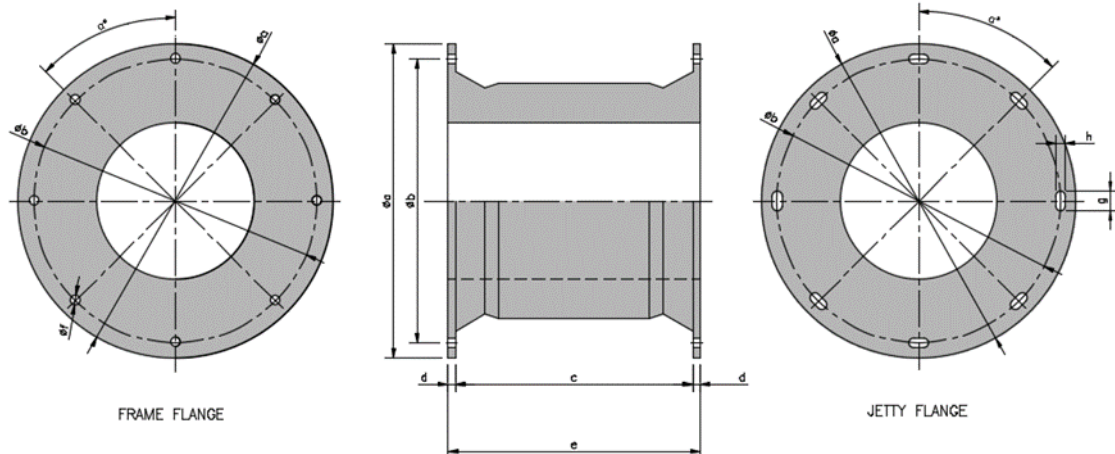

Defensa	a	b	c	d	e	f	g	h	α	Peso (kg)	NºAnclajes/ Métrica
SC-400	650	550	364	18	400	30	60	30	90	62	4xM.22
SC-500	650	556	464	18	500	32	64	32	90	86	4xM.22
SC-630	840	708	580	25	630	40	80	40	90	173	4xM.30
SC-800	1050	900	740	30	800	40	80	40	60	372	6xM.30
SC-1000	1300	1100	930	35	1000	45	90	45	60	679	6xM.36
SC-1150	1500	1300	1076	37	1150	50	108	50	60	968	6xM.42
SC-1250	1650	1450	1170	40	1250	55	110	55	60	1317	6xM.42
SC-1450	1850	1650	1370	40	1450	61	122	61	60	2377	6xM.48
SC-1600	2000	1800	1510	45	1600	60	120	60	45	2538	8xM.48
SC-1700	2100	1900	1610	45	1700	66	130	66	45	3604	8xM.56
SC-2000	2200	2000	1900	50	2000	70	140	70	45	4798	8xM.60
SC-2250	2550	2300	2130	60	2250	75	150	75	36	6700	10xM.64
SC-2500	2950	2700	2360	70	2500	75	150	75	36	10020	10xM.64
SC-3000	3500	3250	2830	85	3000	75	150	75	36	16918	10xM.64

Todas las dimensiones en mm y kg a menos que se indique lo contrario..

3. RENDIMINETO NOMINAL DE LAS DEFENSAS*

Defensa		Calidad				
		A	B	C	D	E
SC-400	R	128	114	98	76	61
	E	19.1	16.9	14.6	11.3	9
SC-500	R	217	193	167	128	103
	E	39.6	35.1	30.4	23.4	18.7
SC-630	R	339	301	256	200	160
	E	76.5	67.9	57.9	45.3	36.2
SC-800	R	508	451	390	300	240
	E	175	155	134	103	83
SC-1000	R	804	714	618	475	381
	E	351	311	270	207	166
SC-1150	R	1065	945	819	630	504
	E	538	477	414	319	255
SC-1250	R	1256	1114	965	742	595
	E	689	611	531	407	326
SC-1450	R	1691	1501	1301	1000	800
	E	1067	948	821	632	505
SC-1600	R	2060	1829	1585	1219	975
	E	1424	1264	1095	843	674
SC-1700	R	2322	2062	1786	1374	1099
	E	1729	1534	1329	1023	819
SC-2000	R	3215	2853	2473	1902	1521
	E	2812	2496	2164	1664	1332
SC-2250	R	4516	4008	3472	2672	2271
	E	4450	3949	3423	2633	2237
SC-2500	R	5777	4949	4289	3299	2805
	E	6161	5468	4739	3645	3088
SC-3000	R	8835	7841	6792	5224	4420
	E	9475	8409	7284	5602	4740

Disponible en otras calidades.

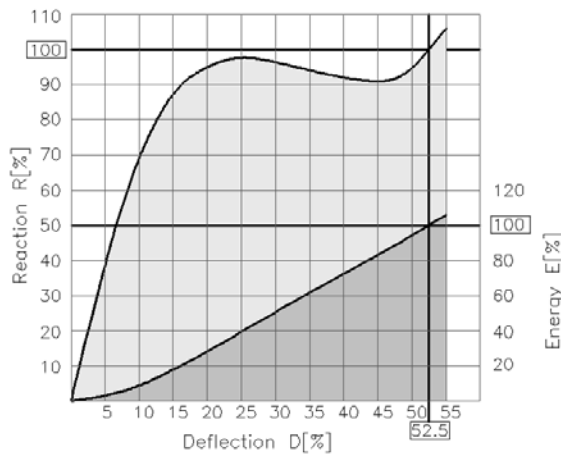

- Factor de temperatura:

Temperatura (°C)	TF
+50	0.9
+40	0.94
+30	0.97
+23	1
+10	1.05
0	1.09
-10	1.16
-20	1.25
-30	1.35

- Factor de Angulo:

Angulo (°)	AF
0	1
3	0.98
5	0.95
8	0.91
10	0.88
15	0.81
20	0.65

- Factor de velocidad

Defensa	Velocidad de impacto (mm/s)						
	1	50	100	150	200	250	300
SC-400	0.87	0.92	0.96	1	1.03	1.06	1.09
SC-500	0.89	0.93	0.96	1	1.03	1.05	1.08
SC-630	0.90	0.93	0.97	1	1.02	1.05	1.07
SC-800	0.91	0.94	0.97	1	1.02	1.04	1.06
SC-1000	0.91	0.94	0.97	1	1.02	1.04	1.06
SC-1150	0.91	0.94	0.97	1	1.02	1.04	1.06
SC-1250	0.91	0.94	0.97	1	1.02	1.04	1.06
SC-1450	0.93	0.96	0.97	1	1.02	1.03	1.05
SC-1600	0.93	0.96	0.97	1	1.02	1.03	1.05
SC-1700	0.93	0.96	0.98	1	1.02	1.03	1.05
SC-2000	0.94	0.96	0.98	1	1.02	1.03	1.05
SC-2250	0.94	0.96	0.98	1	1.02	1.03	1.05
SC-2500	0.95	0.97	0.99	1	1.01	1.02	1.04
SC-3000	0.95	0.97	0.99	1	1.01	1.02	1.04

Grados intermedios																			
A0	A1	A2	A3	B0	B1	B2	B3	C0	C1	C2	C3	D0	D1	D2	D3	E0	E1	E2	E3
20%	8%	5%	3%	15%	10%	7%	4%	15%	13%	9%	4%	15%	12%	10%	6%	20%	11%	7%	3%

Deformaciones intermedias														
D (%)	0	5	10	15	20	25	30	35	40	45	50	52.5	55	
R (%)	0	38	68	86	94	97	95	93	91	90	94	100	108	
E (%)	0	3	9	15	28	39	50	61	72	82	93	100	106	

Todas las dimensiones en mm, kN o kNm a menos que se especifique lo contrario.

* Valores de (E) Energía [kJNm] y (R) Reacción [kN] de acuerdo con PIANC 2002.



4. PESO DEL ESCUDO PERMITIDO

Aunque las defensas SC son capaces de soportar escudos muy pesados, si el escudo a instalar supera los pesos listados en la siguiente tabla es necesario instalar cadenas de sustentación.

Defensa		Calidad				
		A	B	C	D	E
SC-400	H	93	87	81	71	62
	V	140	124	109	93	78
SC-500	H	129	120	112	112	86
	V	194	172	151	151	108
SC-630	H	260	242	225	199	173
	V	389	346	303	260	216
SC-800	H	558	521	484	428	372
	V	837	744	651	558	465
SC-1000	H	1250	1100	950	750	550
	V	1563	1375	1188	938	688
SC-1150	H	1547	1361	1176	928	681
	V	1934	1702	1470	1160	851
SC-1250	H	1861	1637	1414	1116	819
	V	2326	2047	1768	1396	1023
SC-1450	H	2652	2334	2015	1591	1167
	V	3315	2917	2519	1989	1459
SC-1600	H	2758	2427	2096	1655	1214
	V	3448	3034	2620	2069	1517
SC-1700	H	3404	2996	2587	2043	1498
	V	4255	3745	3234	2553	1872
SC-2000	H	3822	3363	2905	2293	1682
	V	4777	4204	3631	2866	2102
SC-2250	H	4938	4346	3753	2963	2173
	V	6173	5432	4691	3704	2716
SC-2500	H	6287	5533	4778	3772	2766
	V	7859	6916	5973	4715	3458
SC-3000	H	8609	7576	6543	5165	3788
	V	10761	9470	8178	6457	4735

Todos los pesos en kg a menos que se indique lo contrario.

(H) Simple o múltiple en posición horizontal. (V) Múltiple vertical.

5. POSICIONAMIENTO DE LA DEFENSA

Defensa	i	j
SC-400	370	240
SC-500	400	300
SC-630	450	378
SC-800	600	480
SC-1000	775	600
SC-1150	900	690
SC-1250	1000	750
SC-1450	1150	870
SC-1600	1250	960
SC-1700	1300	1020
SC-2000	1550	1200
SC-2250	1700	1350
SC-2500	2250	1500
SC-3000	2500	1800

Todas las dimensiones en mm

La distancia i, es la mínima distancia libre a respetar a ambos lados de la defensa.

La distancia j, Es la distancia a respetar entre el escudo y la defensa.

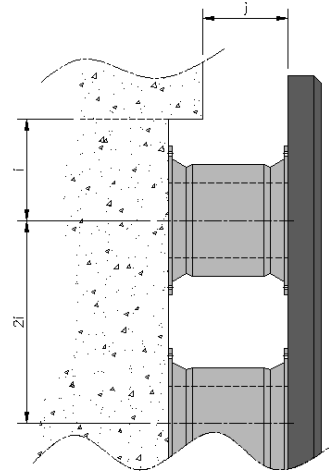

6. TOLERANCIAS

Dimensiones	Tolerancias
Dimensiones generales	±3% o ±2mm*
Distancias entre centros	±4mm (No acumulativos)
Espesor de la brida	±15mm
Diámetros de los puntos de unión	±5mm
Rendimiento de la energía	±10%
Rendimiento de la reacción	±10%

* La mayor de las dos